

**VK**

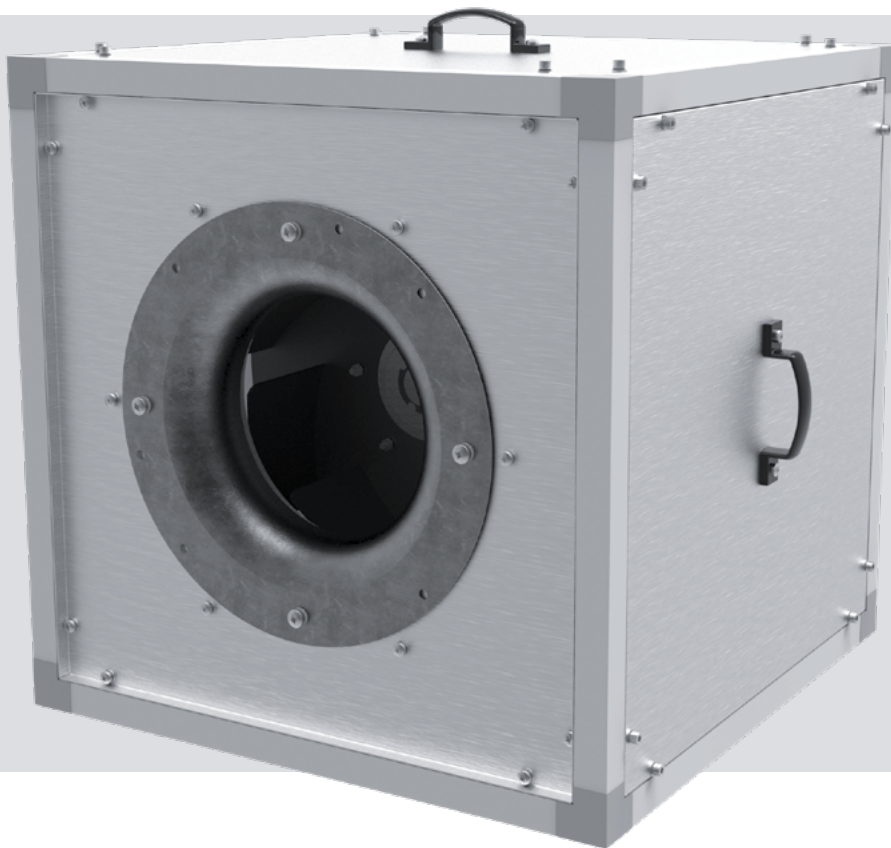

Sound-insulated kitchen fan

---

## CONTENTS

Purpose.....	4
Delivery set.....	4
Designation key.....	4
Technical data.....	5
Design and operating principle .....	9
Mounting and set-up.....	10
Connection to power mains .....	11
Commissioning.....	12
Technical maintenance.....	12
Troubleshooting.....	13
Storage and transportation regulations.....	13
Manufacturer's warranty .....	14
Certificate of acceptance.....	15
Seller information .....	15
Installation certificate.....	15
Warranty card.....	15

This user's manual is a main operating document intended for technical, maintenance, and operating staff.

The manual contains information about purpose, technical details, operating principle, design, and installation of the **VK** unit and all its modifications.

Technical and maintenance staff must have theoretical and practical training in the field of ventilation systems and should be able to work in accordance with workplace safety rules as well as construction norms and standards applicable in the territory of the country.

All operations described in this manual must be performed by qualified personnel only, properly trained and qualified to install, make electrical connections and maintain ventilation units.

Do not attempt to install the product, connect it to the mains, or perform maintenance yourself. This is unsafe and impossible without special knowledge.

Disconnect the power supply prior to any operations with the unit.

All user's manual requirements as well as the provisions of all the applicable local and national construction, electrical, and technical norms and standards must be observed when installing and operating the unit.

Disconnect the unit from the power supply prior to any connection, servicing, maintenance, and repair operations.

Connection of the unit to power mains is allowed by a qualified electrician with a work permit for the electric units up to 1000 V after careful reading of the present user's manual.

Check the unit for any visible damage of the impeller, the casing, and the grille before starting installation. The casing internals must be free of any foreign objects that can damage the impeller blades.

While mounting the unit, avoid compression of the casing! Deformation of the casing may result in motor jam and excessive noise.

Misuse of the unit and any unauthorised modifications are not allowed.

Do not expose the unit to adverse atmospheric agents (rain, sun, etc.).

Transported air must not contain any dust or other solid impurities, sticky substances, or fibrous materials.

Do not use the unit in a hazardous or explosive environment containing spirits, gasoline, insecticides, etc.

Do not close or block the intake or extract vents in order to ensure the efficient air flow.

Do not sit on the unit and do not put objects on it.

The information in this user's manual was correct at the time of the document's preparation.

The Company reserves the right to modify the technical characteristics, design, or configuration of its products at any time in order to incorporate the latest technological developments.

Never touch the unit with wet or damp hands.

Never touch the unit when barefoot.

**BEFORE INSTALLING ADDITIONAL EXTERNAL DEVICES, READ THE RELEVANT USER MANUALS.**



**THE PRODUCT MUST BE DISPOSED SEPARATELY AT THE END OF ITS SERVICE LIFE.  
DO NOT DISPOSE THE UNIT AS UNSORTED DOMESTIC WASTE**

**PURPOSE**



**THE UNIT SHOULD NOT BE OPERATED BY CHILDREN OR PERSONS WITH REDUCED PHYSICAL, MENTAL, OR SENSORY CAPACITIES, OR THOSE WITHOUT THE APPROPRIATE TRAINING.**

**THE UNIT MUST BE INSTALLED AND CONNECTED ONLY BY PROPERLY QUALIFIED PERSONNEL AFTER THE APPROPRIATE BRIEFING.**

**THE CHOICE OF UNIT INSTALLATION LOCATION MUST PREVENT UNAUTHORISED ACCESS BY UNATTENDED CHILDREN.**

The Sound-insulated kitchen fan is designed for exhaust ventilation of kitchens, industrial bakeries, etc. with high temperature and noise requirements and limited installation space. The fan extracts contaminated hot air up to 120 °C, containing grease, in high resistance conditions.

The fan is rated for continuous operation.

The fan is a component part and is not designed for stand-alone operation.

The transported air must not contain flammable or explosive mixtures or chemically active vapours.

**DELIVERY SET**

NAME	NUMBER
Fan	1 pc
User's manual	1 pc
Packing box	1 pc

**DESIGNATION KEY**

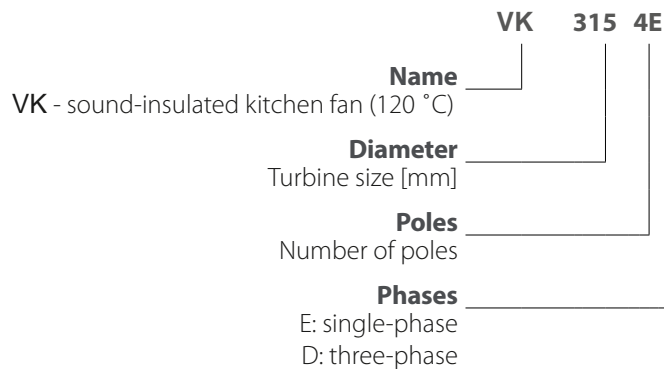

---

## TECHNICAL DATA

The fan is designed for exhaust ventilation of rooms with air temperature from -25 °C to +120 °C.

The unit is rated as a Class I electrical appliance.

The unit design is constantly being improved, thus some models may be different from those described in this manual.

Ingress protection rating of the motor against access to hazardous parts and water ingress is IPX4.

Ingress protection rating of the fan against access to hazardous parts and water ingress is IPX4.



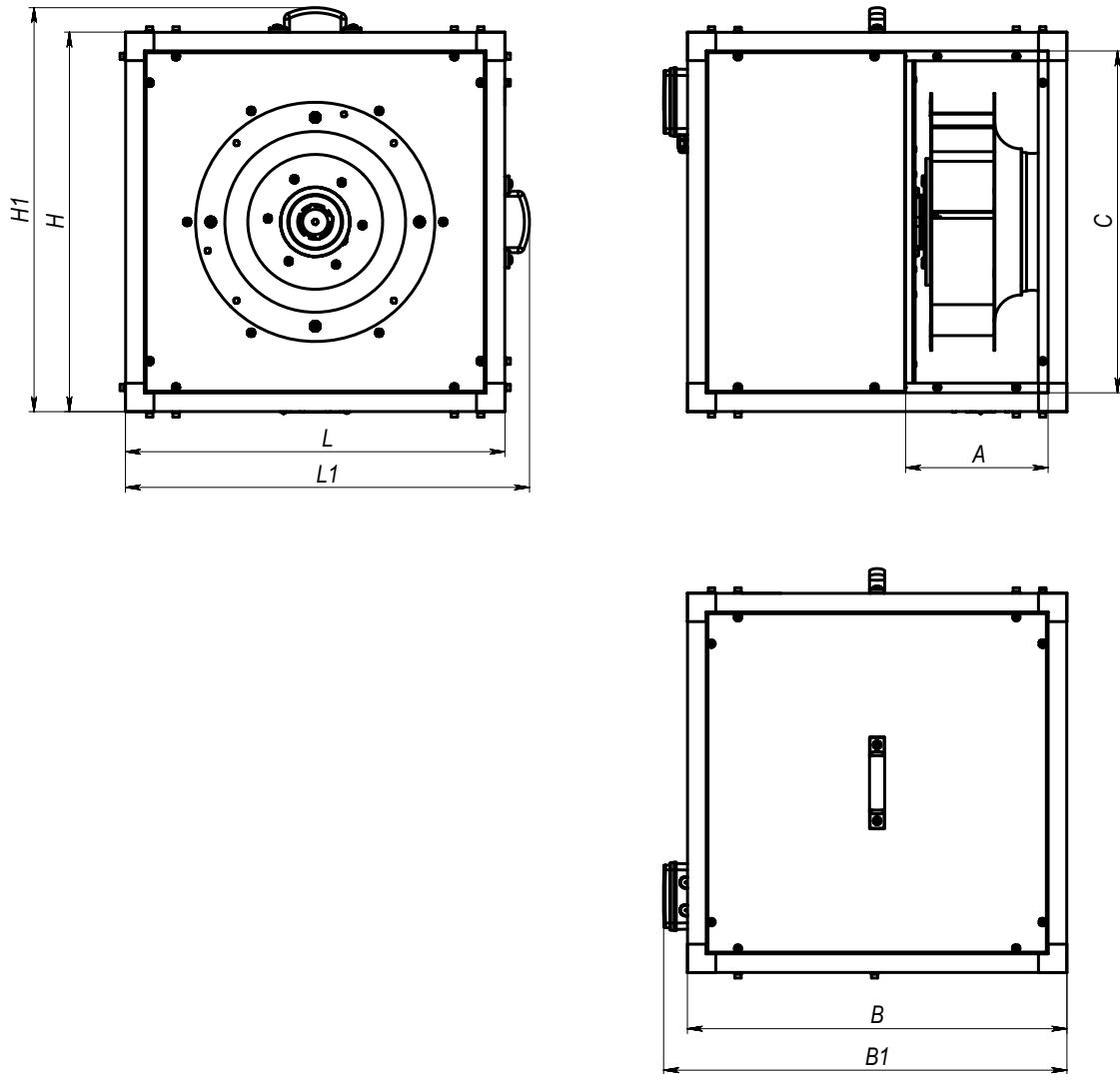

Model	Dimensions [mm]								Weight [kg]
	L	L1	H	H1	B	B1	A	C	
VK 315 2D	500	538	500	538	500	538	200	440	41
VK 315 2E	500	538	500	538	500	538	200	440	40.2
VK 315 4D	500	538	500	538	500	538	200	440	37.2
VK 315 4E	500	538	500	538	500	538	200	440	37.2
VK 355 4D	600	638	600	638	600	638	225	540	48.1
VK 355 4E	600	638	600	638	600	638	225	540	47.4
VK 400 4D	670	708	670	708	670	708	252	610	58.1
VK 400 4E	670	708	670	708	670	708	252	610	60.3
VK 450 4D	700	738	700	738	700	738	282	640	73.3
VK 450 4E	700	738	700	738	700	738	282	640	71.8
VK 500 4D	820	858	820	858	820	858	321	760	101.8
VK 500 4E	820	858	820	858	820	858	321	760	96.3
VK 560 4D	900	938	900	938	900	938	365	840	130.3
VK 630 4D	1000	1038	1000	1038	1000	1038	409	940	173.8
VK 710 6D	1075	1152	1075	1114	1075	1112	455	1015	210
VK 710 4D	1075	1152	1075	1114	1075	1112	455	1015	240
VK 800 6D	1175	1252	1175	1214	1175	1212	505	1115	275

### FAN OPTIONS

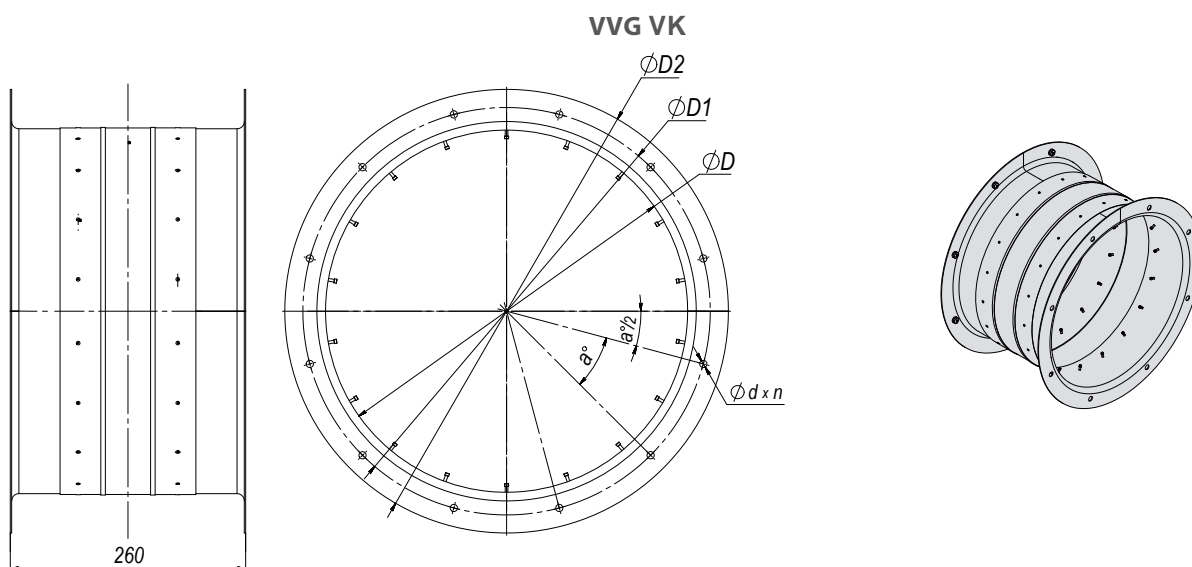

Model	Dimensions [mm]						Weight [kg]
	D	D1	D2	n	a	d	
VVG VK 315	315	365	405	6	60	8	4.76
VVG VK 355	355	395	435	8	45	10	4.08
VVG VK 400	400	450	490	12	30	8	4.76
VVG VK 450	450	500	540	12	30	8	5.34
VVG VK 500	500	560	600	12	30	12	6.12
VVG VK 560	560	620	660	12	30	12	6.83
VVG VK 630	630	690	730	12	30	12	7.66
VVG VK 710	710	770	810	16	22.5	12	8.6
VVG VK 800	800	860	900	16	22.5	12	9.67

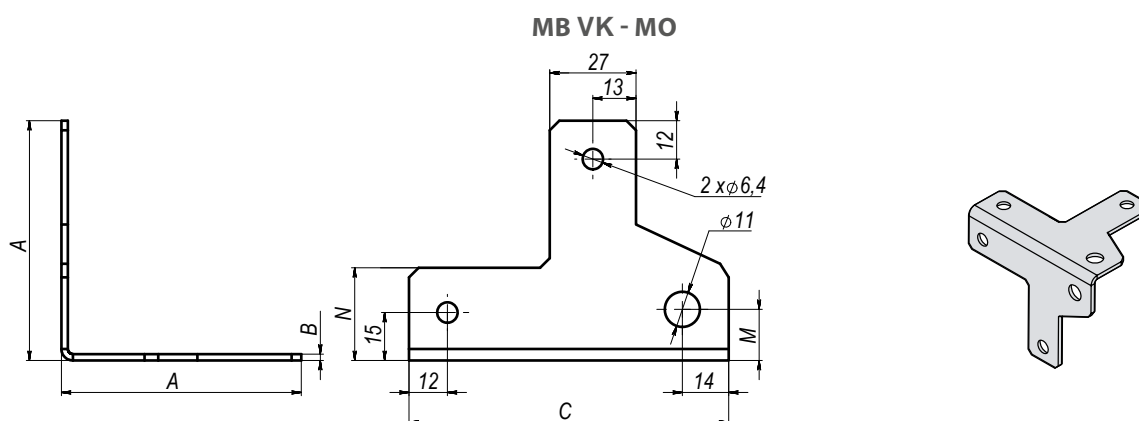

Model	Dimensions [mm]				
	A	B	C	N	M
MB VK - MO 315...450	75	2	100	29	16
MB VK - MO 500...800	85	3	110	30	18

**VPR VK**

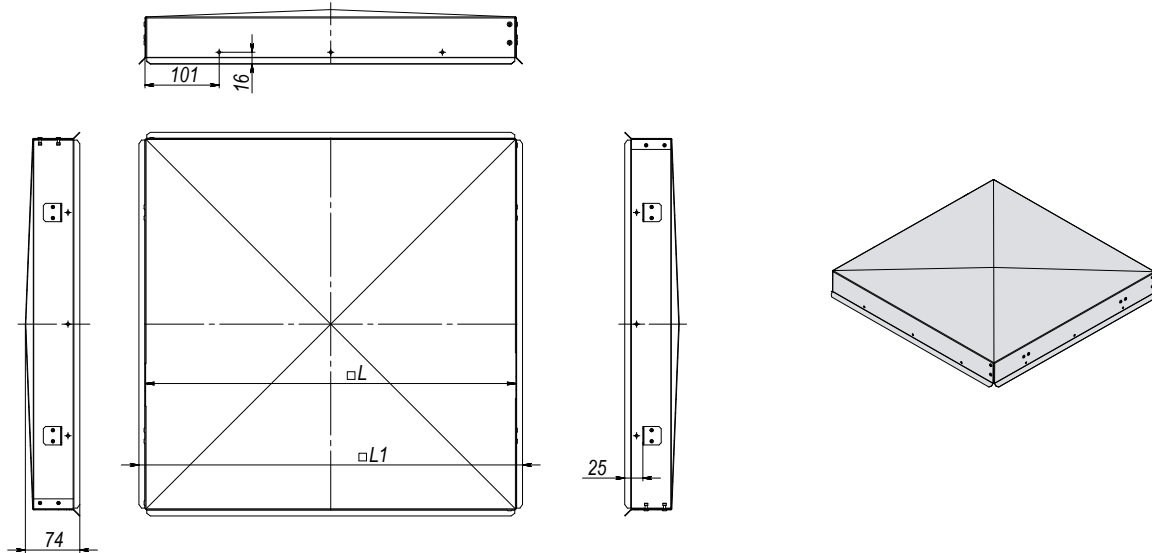

Model	Dimensions [mm]		Weight [kg]
	L	L1	
VPR VK 315	503	522	2.42
VPR VK 355	603	622	3.25
VPR VK 400	673	692	3.91
VPR VK 450	703	722	4.21
VPR VK 500	823	842	6.57
VPR VK 560	903	922	7.71
VPR VK 630	1003	1022	9.27
VPR VK 710	1078	1097	10.53
VPR VK 800	1178	1197	12.3

**RF VK**

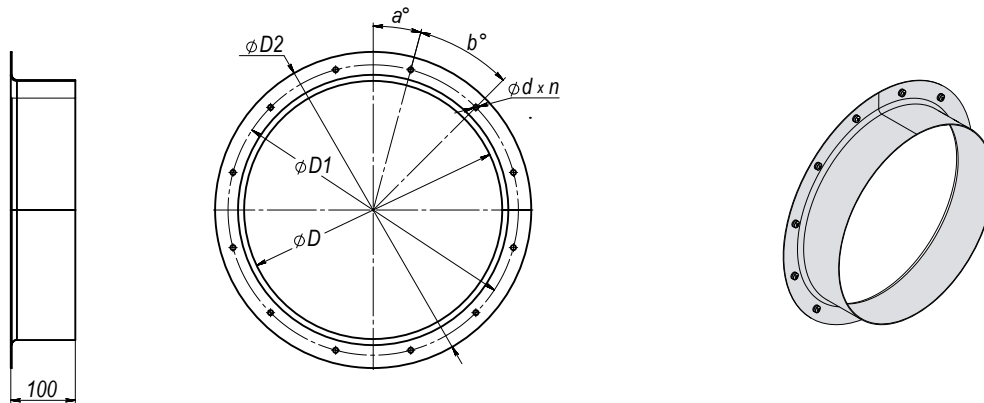

Model	Dimensions [mm]					a°	b°	Weight [kg]
	D	D1	D2	d	n			
RF VK 315	315	365	405	8	6	15	60	1.7
RF VK 355	355	405	445	8	6	15	60	1.9
RF VK 400	400	450	490	8	12	15	30	2.13
RF VK 450	450	500	540	8	12	15	30	2.39
RF VK 500	500	560	600	12	12	15	30	2.75
RF VK 560	560	620	660	12	12	15	30	3.06
RF VK 630	630	690	730	12	12	15	30	3.44
RF VK 710	710	770	810	12	16	11.25	22.5	3.86
RF VK 800	800	860	900	12	16	11.25	22.5	4.34

## DESIGN AND OPERATING PRINCIPLE

The fan casing is made of an aluminium frame fastened with aluminium corners and removable heat- and sound-insulated double-layer panels made of aluzinc.

Thanks to its corrosion-resistant aluzinc casing and heat-insulation material, the fan is suitable for outdoor installation.

The **VK** fan is equipped with an asynchronous motor with an external rotor and a centrifugal impeller with backward curved blades. The fan has a special design that allows you to change the position of the side panels for air supply in directions at an angle of 90°.

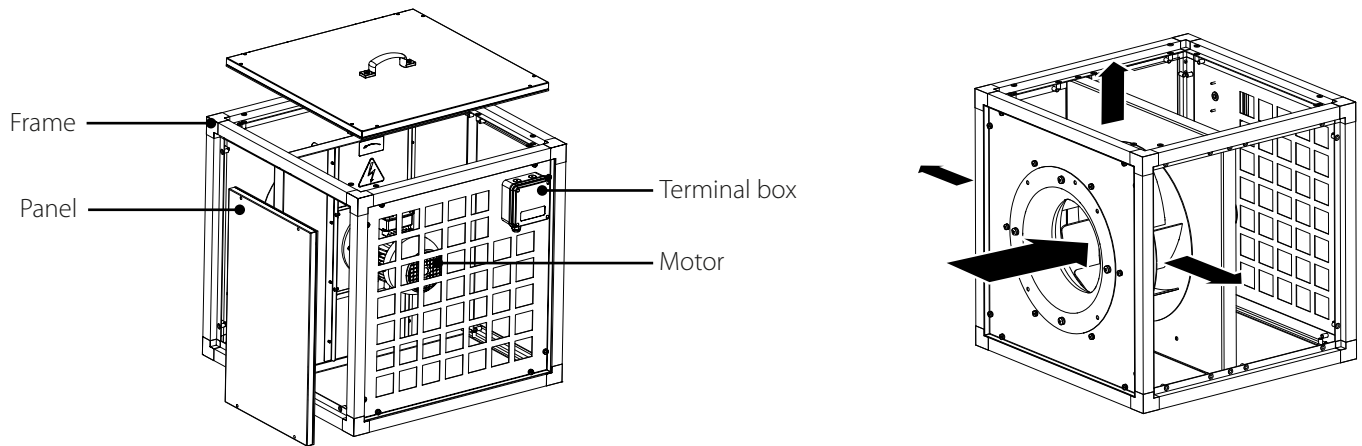

When connecting the fan to the air duct system, it is recommended to use the accessories specified in the User's manual.

Connecting spigots can be of round cross-section.

Connecting spigots and accessories are not included in the delivery set, they are ordered separately.

### Connecting accessories

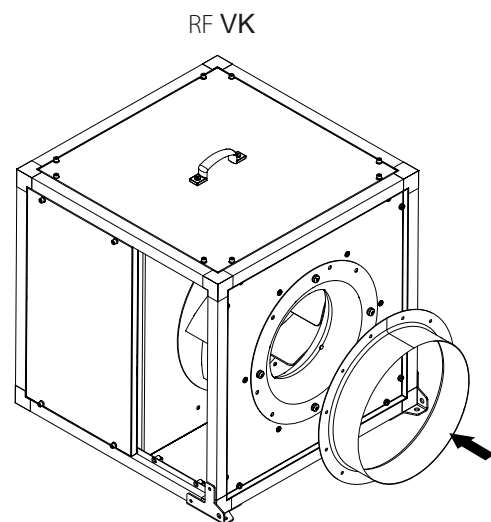
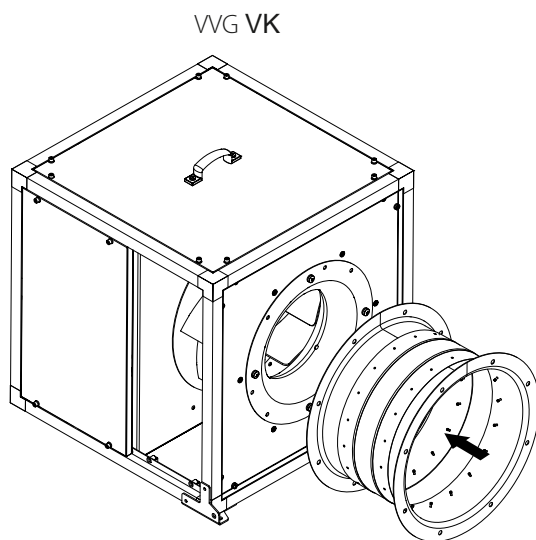

## MOUNTING AND SET-UP



**BEFORE MOUNTING MAKE SURE THE CASING DOES NOT CONTAIN ANY FOREIGN OBJECTS (E.G. FOIL, PAPER).**



**WHILE INSTALLING THE UNIT ENSURE CONVENIENT ACCESS FOR SUBSEQUENT MAINTENANCE AND REPAIR.**

Before installing the fan, make sure that there is no visible damage to the impeller and check the integrity of the insulation of the power supply wires.

The impeller must rotate freely without touching the flange and casing.

The fan must be installed in an air duct of similar diameter.

The fan must be mounted in such a way that the direction of the air flow arrow on the fan casing coincides with the direction of air in the system. The fans are installed between the air ducts.

The connection to the air ducts is carried out using an appropriately sized flexible adapter.

In case of mounting the fan on flexible joints, attach the fan to a structural unit by means of brackets.

The fan can be mounted in any position according to the direction of air flow (indicated by the arrow on the fan casing).

To attain the best performance of the fan and to minimize turbulence-induced air pressure losses while mounting, connect the straight air duct section to the fan spigots on both sides of the fan. The minimum straight air duct length is equal to 1 air duct diameter on the intake side and 3 air duct diameters on the exhaust side.

No filters or other devices must be installed in these sections.

The fan is not a ready to use unit and requires connection to the air ducts.

Install the fan securely while ensuring free access for maintenance operations, the required distance to the walls of the room is at least 1 m.

The **VK** fan is equipped with a drain fitting for connection to the drainage system.

Fan installation sequence:

- Before installation, route the wires and cables necessary to connect the fan to the mains.
- Make sure that the motor is not energized.
- Fasten the MK **VK** brackets in accordance with the supporting plane (structure).
- Fix the fan to the MK **VK** mounting brackets using suitable fasteners (e.g. dowels).
- Connect the air ducts to the fan.

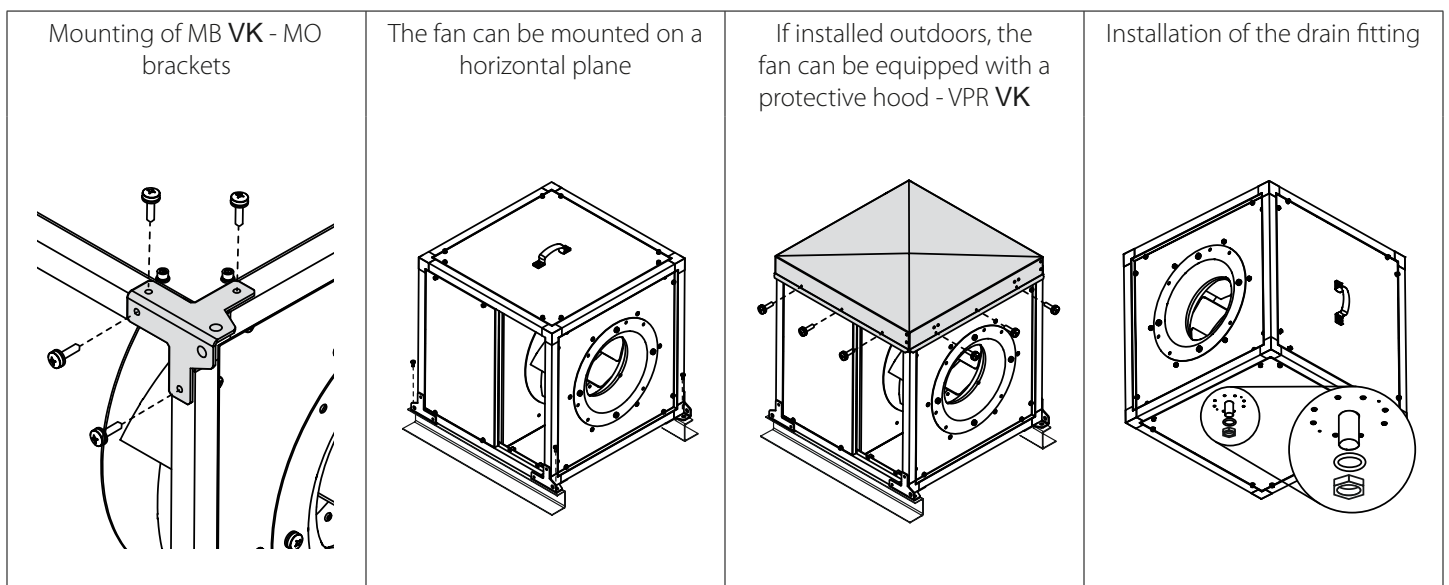

The MK **VK** brackets and the VPR **VK** protective hood are not included in the delivery set and must be ordered separately.

## CONNECTION TO POWER MAINS



**DISCONNECT THE POWER SUPPLY PRIOR TO ANY OPERATIONS WITH THE UNIT.**

**CONNECTION OF THE UNIT TO POWER MAINS IS ALLOWED BY A QUALIFIED ELECTRICIAN WITH A WORK PERMIT FOR THE ELECTRIC UNITS UP TO 1000 V AFTER CAREFUL READING OF THE PRESENT USER'S MANUAL.**

**THE RATED ELECTRICAL PARAMETERS OF THE UNIT ARE GIVEN ON THE MANUFACTURER'S LABEL.**

- The unit is rated for connection to power mains with the parameters specified in the "Technical data" section, according to the wiring diagram.
  - The connection must be made using durable, insulated and heat-resistant conductors (cables, wires). The actual wire cross section selection must be based on the maximum load current, maximum conductor temperature depending on the wire type, insulation, length and installation method.
  - The unit must be connected to a stationary power supply network in accordance with the applicable regulations.
- The electrical connection must be made at the terminal board of the terminal box located on the fan casing in accordance with the wiring diagram and terminal designation.
- The wiring diagram label is located inside the terminal box.

### Power supply parameters and examples of fan wiring diagrams

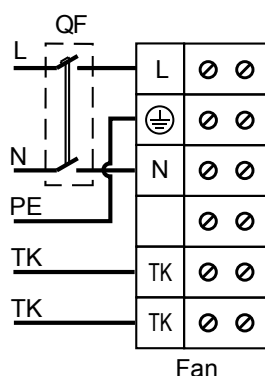

1~230 V

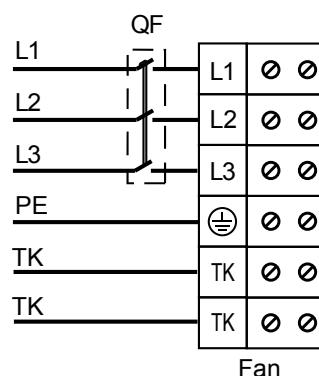

3~400 V

### Designation

L(x) – phase N – neutral QF – automatic circuit breaker PE - ground wire TK - motor thermal protection contacts



**MAKE SURE THAT THE FAN IMPELLER ROTATES IN THE DIRECTION MARKED BY THE ARROW ON THE FAN CASING.**

**IF NECESSARY, CHANGE THE IMPELLER ROTATION DIRECTION BY ALTERING THE PHASE SEQUENCE ON THE ELECTRIC MOTOR TERMINALS.**

## COMMISSIONING



**THE ORGANISATION RESPONSIBLE FOR THE COMMISSIONING SHALL BE RESPONSIBLE FOR PROPER MOTOR PHASING AND STARTING PATTERN SELECTION.**



**DURING STARTING THE IN-RUSH CURRENTS OF THE FAN MAY SEVERAL TIMES EXCEED THE RATED VALUES.**

**SEE "ASYNCHRONOUS ELECTRIC MOTOR STARTING METHODS" IN THE "CONNECTION TO POWER MAINS" SECTION**

- After fan starting make sure that the electric motor rotates properly without undue vibration and abnormal noise.
- Make sure that the fan impeller rotates in the direction marked by the arrow on the fan casing. If necessary, change the rotation direction of the impeller by reversing the phase sequence (for a three-phase motor) or by rewiring according to the wiring diagram located inside the terminal box (for a single-phase motor).
- Make sure that the fan energy consumption complies with the value given on the equipment nameplate and check the motor for overheating.
- The phase current should be checked once the fan reaches the rated operating conditions.
- Do not switch the fan on and off several times without pauses as this may result in damage to the winding or insulation due to overheating.

## TECHNICAL MAINTENANCE



**DISCONNECT THE UNIT FROM POWER SUPPLY BEFORE ANY MAINTENANCE OPERATIONS!**

**MAKE SURE THE UNIT IS DISCONNECTED FROM POWER MAINS BEFORE REMOVING THE PROTECTION**

- The technical maintenance includes periodic cleaning of the surfaces from accumulated dust and dirt.
- When carrying out fan maintenance, it is necessary to partially disassemble it in order to access contaminated parts of the fan.
- To do this, unscrew the screws, remove the cover from the casing.
- The impeller blades require thorough cleaning every 6 months.
- Use a soft, dry cloth or compressed air to remove dust.
- Carry out wet cleaning using warm water and a mild household detergent.
- Protect the electric motor against liquid ingress.
- Do not immerse the unit in water!
- Do not use aggressive solvents, sharp objects, etc. to clean the unit to prevent damage to the impeller.

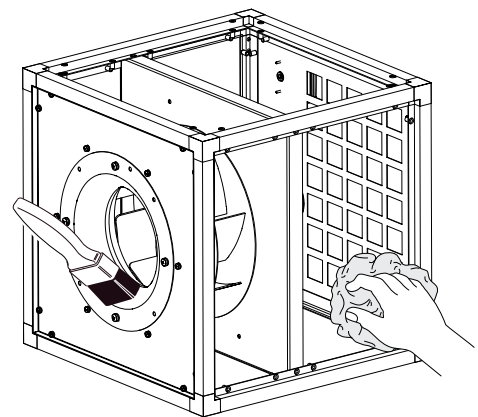
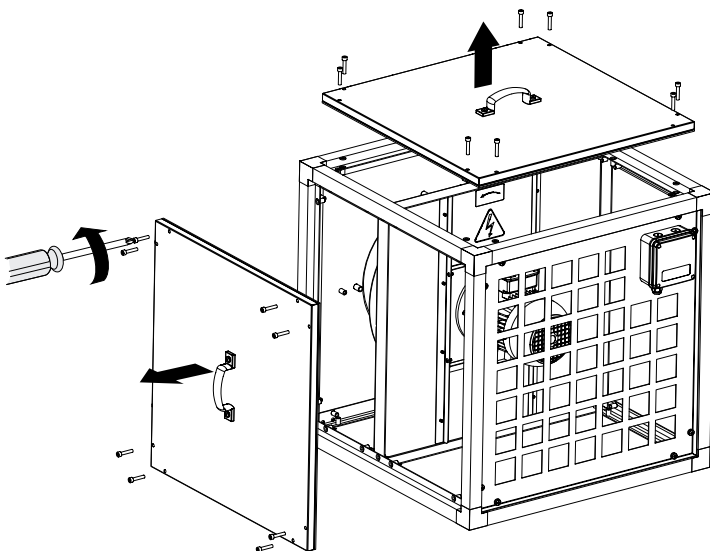

## TROUBLESHOOTING

PROBLEM	POSSIBLE REASONS	TROUBLESHOOTING
Fan does not run.	No power supply.	Make sure the power supply line is connected correctly, otherwise troubleshoot the connection error.
Low air flow.	The ventilation system is soiled or damaged.	Make sure the air ducts are clean. Clean them if necessary.
Noise, vibration.	The impellers are soiled.	Clean the impeller.
	The screw connection is loose.	Tighten the fixing screws.

## STORAGE AND TRANSPORTATION REGULATIONS

- Store the unit in the manufacturer's original packaging box in a dry closed ventilated premise with temperature range from +5 °C to + 40 °C and relative humidity up to 70 %.
- Storage environment must not contain aggressive vapors and chemical mixtures provoking corrosion, insulation, and sealing deformation.
- Use suitable hoist machinery for handling and storage operations to prevent possible damage to the unit.
- Follow the handling requirements applicable for the particular type of cargo.
- The unit can be carried in the original packaging by any mode of transport provided proper protection against precipitation and mechanical damage. The unit must be transported only in the working position.
- Avoid sharp blows, scratches, or rough handling during loading and unloading.
- Prior to the initial power-up after transportation at low temperatures, allow the unit to warm up at operating temperature for at least 3-4 hours.

## SAFETY MEASURES DURING LOADING AND UNLOADING AND INSTALLATION



**CAUTION!**  
**BE CAREFUL DURING LOADING AND UNLOADING OPERATIONS!**

- Be sure to take into account the weight of the unit and the lifting capacity of the handling equipment.
- Transport the fan using suitable means of transportation: a lifting crane, traverse or forklift.
- Always ensure that the side panels are protected from damage by the forklift or cables.
- Choose slings of such length as to ensure even distribution of the load.
- Wear protective gloves and safety shoes when working.
- Avoid impacts and jolts during transportation.
- Manipulation should only be carried out using suitable lifting equipment.
- Never stand under a suspended fan!

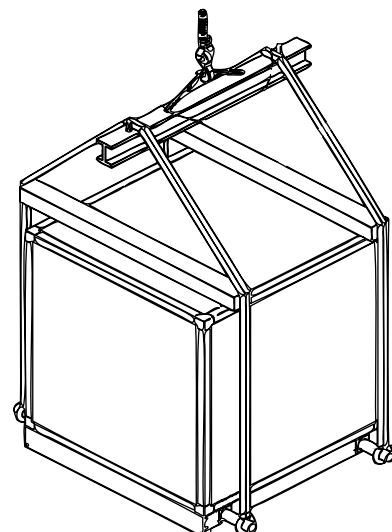

## MANUFACTURER'S WARRANTY

The product is in compliance with EU norms and standards on low voltage guidelines and electromagnetic compatibility. We hereby declare that the product complies with the provisions of Electromagnetic Compatibility (EMC) Directive 2014/30/EU of the European Parliament and of the Council, Low Voltage Directive (LVD) 2014/35/EU of the European Parliament and of the Council and CE-marking Council Directive 93/68/EEC. This certificate is issued following test carried out on samples of the product referred to above.

The manufacturer hereby warrants normal operation of the unit for 24 months after the retail sale date provided the user's observance of the transportation, storage, installation, and operation regulations. Should any malfunctions occur in the course of the unit operation through the Manufacturer's fault during the guaranteed period of operation, the user is entitled to get all the faults eliminated by the manufacturer by means of warranty repair at the factory free of charge. The warranty repair includes work specific to elimination of faults in the unit operation to ensure its intended use by the user within the guaranteed period of operation. The faults are eliminated by means of replacement or repair of the unit components or a specific part of such unit component.

### The warranty repair does not include:

- routine technical maintenance
- unit installation/dismantling
- unit setup

To benefit from warranty repair, the user must provide the unit, the user's manual with the purchase date stamp, and the payment paperwork certifying the purchase. The unit model must comply with the one stated in the user's manual. Contact the Seller for warranty service.

### The manufacturer's warranty does not apply to the following cases:

- User's failure to submit the unit with the entire delivery package as stated in the user's manual including submission with missing component parts previously dismantled by the user.
- Mismatch of the unit model and the brand name with the information stated on the unit packaging and in the user's manual.
- User's failure to ensure timely technical maintenance of the unit.
- External damage to the unit casing (excluding external modifications as required for installation) and internal components caused by the user.
- Redesign or engineering changes to the unit.
- Replacement and use of any assemblies, parts and components not approved by the manufacturer.
- Unit misuse.
- Violation of the unit installation regulations by the user.
- Violation of the unit control regulations by the user.
- Unit connection to power mains with a voltage different from the one stated in the user's manual.
- Unit breakdown due to voltage surges in power mains.
- Discretionary repair of the unit by the user.
- Unit repair by any persons without the manufacturer's authorization.
- Expiration of the unit warranty period.
- Violation of the unit transportation regulations by the user.
- Violation of the unit storage regulations by the user.
- Wrongful actions against the unit committed by third parties.
- Unit breakdown due to circumstances of insuperable force (fire, flood, earthquake, war, hostilities of any kind, blockades).
- Missing seals if provided by the user's manual.
- Failure to submit the user's manual with the unit purchase date stamp.
- Missing payment paperwork certifying the unit purchase.



**FOLLOWING THE REGULATIONS STIPULATED HEREIN WILL ENSURE A LONG AND TROUBLE-FREE OPERATION OF THE UNIT.**



**USER'S WARRANTY CLAIMS SHALL BE SUBJECT TO REVIEW ONLY UPON PRESENTATION OF THE UNIT, THE PAYMENT DOCUMENT AND THE USER'S MANUAL WITH THE PURCHASE DATE STAMP.**

## CERTIFICATE OF ACCEPTANCE

<b>Unit Type</b>	Sound-insulated kitchen fan
<b>Model</b>	
<b>Serial Number</b>	
<b>Manufacture Date</b>	
<b>Quality Inspector's Stamp</b>	

## SELLER INFORMATION

<b>Seller</b>	
<b>Address</b>	
<b>Phone Number</b>	
<b>E-mail</b>	
<b>Purchase Date</b>	
This is to certify acceptance of the complete unit delivery with the user's manual. The warranty terms are acknowledged and accepted.	
<b>Customer's Signature</b>	

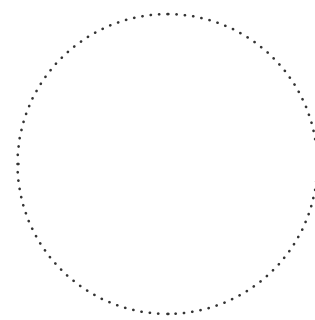

Seller's Stamp

## INSTALLATION CERTIFICATE

The _____ unit is installed pursuant to the requirements stated in the present user's manual.	
<b>Company name</b>	
<b>Address</b>	
<b>Phone Number</b>	
<b>Installation Technician's Full Name</b>	
<b>Installation Date:</b>	<b>Signature:</b>
The unit has been installed in accordance with the provisions of all the applicable local and national construction, electrical and technical codes and standards. The unit operates normally as intended by the manufacturer.	
<b>Signature:</b>	

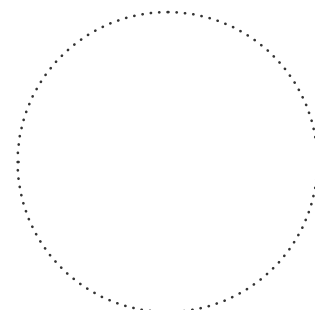

Installation Stamp

## WARRANTY CARD

<b>Unit Type</b>	Sound-insulated kitchen fan
<b>Model</b>	
<b>Serial Number</b>	
<b>Manufacture Date</b>	
<b>Purchase Date</b>	
<b>Warranty Period</b>	
<b>Seller</b>	

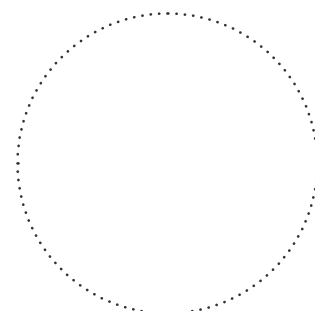

Seller's Stamp